

SPECIFICATI ON BOOK



2019/2020

DIRT SERIES

Motor racing is a sport – a dangerous sport – but a good sport is made up of men and women.

This is no place for the troublemaker or the person who can see nothing but wrong. Believing that every action of the officials is directed at them; that rules are made only for them to break. This person has no place in the sport of motor racing.

Glenn Perret

**Executive member Formula 500's
Australia**



FORWORD

Legend Cars Australia officials attempt to be fair and maintain consistency with the application of these specifications.

Our objectives are fairness and safety.

For an organisation to be successful, it must have good rules and enforce them fairly and consistently.

Cooperation between officials and competitors will assure our sport a bright future.

After a race car has passed scrutineering, it may not be altered to any specification that would make it illegal.

Any race car that has passed scrutineering may still be subject to further inspection at the discretion of scrutineers and may be excluded from the event and driver suspended.

Please be advised that all rules will be applied as per this specification book and the onus falls to the driver to ensure he is familiar with this rule book.

Please do not try and bring a race car that is out of 'spec', as you will be required to bring it back to 'spec' at the track before being permitted to compete.

Scrutineering is required to ensure all race cars are safe and evenly matched.

It is in YOUR OWN INTERESTS to present a LEGAL and SAFE race car.

Thank you.

Table of Contents

PART ONE Safety Equipment, Fire Extinguisher, Seats

PART TWO Legend Car Specification Rules

PART THREE Index

1	Aerodynamics	40	Gussets
2	Air Filters	41	Heim Ends
3	Alternators	42	Ignition System
4	Ball Joints	43	Ignition Control Box
5	Ballast	44	Ignition Rotors
6	Battery	45	Ignition Plates
7	Bolts and Fasteners	46	Jam Nuts
8	Brakes	47	Kill Switch
9	Bump Steer	48	Lower Control Arms
10	Bumpers and Tow Hooks	49	Mandatory Decals
11	Bumper Straps	50	Mirrors
12	Carbon Fibre	51	Mufflers
13	Carburetors	52	Nerf Bars
14	Car/Door Numbers	53	Oil Catch Cans
15	Car Weight	54	Oil Coolers and Lines
16	Chrome Plating and Polishing	55	Pickup Point and Spacers
17	Clutch Master Cylinder	56	Rack and Pinion Steering
18	Coils, Coil Leads and Spark Plug Boots	57	Race Car Appearance
19	Drive Shaft	58	Radius Rods and Panhard Bar
20	Engine Coatings	59	Rear Axles
21	Engine Cooling	60	Rear Ends
22	Engine Serial Numbers	61	Rear Offset
23	Engine Location and Mounts	62	Remote Oil Filters.
24	Engines	63	Ride Height
25	Exhaust System	64	Running Boards
26	Fender Mounting	65	Sheet Metal
27	Fender Holes and Trimming	66	Shock Absorbers
28	Fibreglass Components	67	Spindles
29	Firewall	68	Springs
30	Frame	69	Sprocket Adaptors
31	Fuel	70	Steering Column
32	Fuel Cell	71	Steering Wheels
33	Fuel Filters	72	Traction Control Devices
34	Fuel Lines	73	Tyres
35	Fuel Valves and Regulators	74	Upper Control Arms
36	Fuel Pump	75	Wheelbase
37	Gauges & Switches	76	Wheels
38	Gear Ratios	77	Width
39	Gear Shifter & Knob	78	Windshields

PART FOUR

CAMSHAFTS

CLUTCH

CYLINDER HEADS

PART FIVE

VALVES

TRANSMISSION

OIL PANS AND OILING SYSTEMS

PART SIX

REGISTRATIONS

NOMINATIONS

TRANSPONDERS

~~~~~

**PART ONE**

**SAFETY EQUIPMENT**

All personal safety equipment shall be compliant with the regulations as set down by the governing body level of licencing. A Horse Collar may be used for practice or 2 Seater laps.

Head & Neck restraints ***are mandatory*** for the 18/19 season.

All cars must be fitted with an approved 5 or 6 point racing harness mounted to the manufacturers mounting points or the equivalent to the scrutineer’s satisfaction with minimum 8 mm diameter high grade bolts and nylox nuts with the thread of the bolt protruding into the section of the nut. All safety harnesses are to be no more than 2 years old from the date stamped on the SFI tag regardless of how many times the car has been raced. Any belts that are frayed, torn or in the opinion of the scrutineer, damaged, need to be replaced before competing. It is strongly recommended by the manufacturers of Safety Harnesses that should the harness be involved in a major impact they be replaced immediately.

Arm restraints ***are mandatory*** for the 18/19 Season.

Drivers **MUST** install roll bar padding on sections of rollbars that may come into contact with the helmet in the event of an impact. Roll Bar padding is **mandatory** in all cars.

**FIRE EXTINGUISHER**

A 1.0 kg dry powder fire extinguisher is ***optional***. If fire extinguisher is fitted it must comply with all conditions as per Speedway Australia. Fire Extinguishers are to be fitted in front of seat under driver’s legs and must be bolted in position with satisfactory clamping device.

**SEATS**

Only factory manufactured seats approved by INEX or LCA may be used. **NO** homemade seats. Lightening of the seat by anyone other than the manufacturer is prohibited. **NO** alterations to framework bars are to be carried out to mount the seat. If altering the seat for safety and comfort the front seat mounting brackets (two of) may be modified. The modified mountings must still be welded to the floor seat mounting rail (this rail position cannot be changed). If the seat mountings are longer than the originals then they should be suitably reinforced or made of heavier material in proportion to their length. The rear seat mountings cannot be altered. Seats are not to be directly mounted to the floor. All bolts must be a minimum 8mm (0.32in) bolts with minimum 35 mm (1.38 in) backing washers, with the thread of the bolt protruding into the section of the nut, on the seat to prevent bolts pulling through the seat in the event of an impact. No drilling through bar work allowed. All seat mountings are to be to the satisfaction of the presiding technical inspector.

## **PART TWO**

### **LEGEND CAR SPECIFICATION RULES**

Upon entering a Legend Car for competition any car may be checked for engine, chassis, fuel, tyres, wheels, suspension or any other component to confirm legality at any time by an official or representative of LCA.

The driver of the car is responsible for ensuring the legality of a car entering into competition, and will be the person that will suffer all resulting penalties. Refusal to allow any part of a car to be inspected by an official of LCA will result in immediate disqualification and possible suspension from future events in Legend Cars.

Drivers are responsible for the conduct of themselves, pit crew and associates involved with the driver and car. Any breach of misconduct in regards to abuse of another driver, official, pit crew or associates whether verbal or physical from the above mentioned during the course of a race meeting, will result in immediate disqualification from the event and further penalties will be imposed by LCA/ALCA at a later date.

***If this rule book does not specifically say that you can change, modify, add or remove something then you must consider that the change, modification, addition or removal of that item is ILLEGAL.***

Any enquiries regarding the change, modification, addition or removal of any item of the race car must be submitted in writing to LCA with all supporting documentation.

LCA reserve the right to trial new components at their discretion.

#### **DEFINITION OF TERMS USED:**

“LCA” – Legend Cars Australia, deemed the sole manufacturer of Legend Cars in Australia.

“INEX/LCA” – Interprets and enforces the specification rules for all Legend Cars.

“ALCA” – Australian Legend Car Association. Independent to LCA and INEX.

“Stock” or “Original Equipment Manufacturer/OEM” as delivered “new” from U.S. Legend Cars International or at the current standards of US Legend Cars International or LCA.

“Disqualification” – unless otherwise defined will mean the forfeiture of all awards, prizes and points earned for and prior to the infraction during the date(s) of the event.

“Competition/Race” – A contest in which an INEX driver takes part and which is of a competitive nature or is given a competitive nature by the publication of results.

“Event” – An entire program of on track, INEX or LCA competitions or races, including practice.

Every event which uses the name “Legend Car/s” or “INEX” or any likeness to the name or logo must be formally approved by INEX or LCA.

“Unauthorized” use of the name by events or people will be vigorously prosecuted to the fullest extent.

**U.S. Legend Cars International and LCA when used in the current INEX Rulebook, will be considered the same entity.**

## **COMPETITION RULES**

All new and second hand cars eligible for competition in Australia will be sourced through U.S. Legend Cars. VIN number, registration papers, and validity of cars will be checked by USLCI in the USA and upon arrival in Australia, will be checked and registered by LCA.

Log books will be supplied for all cars by Legend Cars Australia. Any driver who fails to produce the Log Book for his car at any given event will be ineligible to compete in that event. Log Books will remain the property of LCA and we reserve the right to recall at any time.

All Legend Car drivers will be INEX members and will have a membership number. These individuals will be eligible for National and International Championships.

All cars eligible for competition in Australia will be registered by LCA and will have a Registration sticker dated from 1 July to 30 June each year, at a cost of **\$260** for the current year. This cost covers Registration, INEX membership for the year and Log Book. Log Books are valid for 3 seasons.

All cars and frames racing as Legend Cars must have been produced by USLCI and stamped by INEX or LCA.

Cars not registered with LCA and not having a registration sticker approved by LCA will not be eligible to compete in Australia. Current LCA Registration and up to date LCA Log Book must be available at all times.

All drivers must be a member of ALCA.

No Registered Legend Car will be permitted to compete on any track, at any event not sanctioned by Legend Cars Australia unless express permission has been granted by LCA. Any driver in breach of this rule will receive a minimum 12 month suspension with their car/s immediate deregistration and Log Books returned to Legend Cars Australia within 10 business days.

The first calendar date marks the start of the season, and any events added to the existing calendar after this time will automatically be non-points rounds.

## **GENERAL**

At each race meeting, cars will be self-scrutineered by the driver when setting up their pit area. The driver must complete the event information in his/her Log Book and sign off as fit to compete. The Log Book should then be left with the car for Track Scrutineers. Track scrutineering will be carried out at the discretion of the venue. Any driver who fails to attend scrutineering or a weigh in directly after a race, if requested, will face disqualification unless prior arrangements have been made with LCA. In addition random spot checks by INEX/LCA may be performed. Log books must be presented on request or that car will not be permitted to race.

All personal safety gear as per Speedway Australia Rules & Regulations.

Only INEX or LCA stamped parts will be deemed legal unless otherwise stated.

A Log Book will be issued to ALL cars by LCA as part of Registration. Loss of this Log book will incur a fee of \$100 for replacement.

## **PART THREE**

### **INDEX**

#### **1. AERODYNAMICS**

Spoilers or any other devices that affect aerodynamics are not permitted.

#### **2. AIR FILTERS**

Only stock or K&N air filters and outerwear pre filters are permitted. No device that directs airflow to the carburetors or increases air flow is permitted.

#### **3. ALTERNATORS**

Modification to the charging system is not permitted. The alternator must be charging at all times. No switches disconnecting the alternator are permitted. The engine must continue to run at idle with the battery disconnected.

#### **4. BALL JOINTS**

All ball joints to remain standard as supplied and stamped by INEX or LCA. One jam nut minimum per ball joint. No welding of ball joints or jam nuts.

#### **5. BALLAST**

A maximum of eight blocks of lead are permitted. Blocks must be no larger than 38mm x 65mm x 300mm. Stacking of blocks is not permitted. All blocks must be painted in a bright colour and numbered with the car number. The ballast must be lead. Ballast must be mounted directly onto the rectangular chassis section with minimum 2 mm x 8 mm bolts per block. All ballast must have a minimum ground clearance of 85mm. Ballast is not to be installed forward of the front frame horns or in the drivers compartment. All mounting of ballast is subject to approval by scrutineers.

#### **6. BATTERY**

Only one acid or gel battery minimum 25lbs (11.3 kg) may be used. Approximate dimensions are 7 1/8" x 8" x 6 1/2" (18cm x 20.3cm x 16.5cm). Top or side post type may be used.

Motorcycle batteries are not permitted. The battery must remain in its stock location and securely mounted. The original battery cradle and bracket must not be altered in any way. Terminal covers and rubber cover over battery are recommended.

**A battery isolator switch is optional.**

## **7. BOLTS AND FASTENERS**

Only equivalent stock or upgraded steel fasteners and bolts may be used on Legend Cars. Fasteners may be drilled for safety wires, however intentional weight saving modifications are not permitted. Aluminium and titanium bolts are not permitted.

## **8. BRAKES**

All brake components that attach to the diff housing or front spindles must be stock size, dimension, configuration, thickness and location as supplied by USLCI and stamped by INEX or LCA. All brakes are to be operational. Brake lines or calipers are not to be plugged off or shut off causing non operation.

**NO** drilling or lightening of discs or drums.

Minimum thickness of discs is 8mm.

Minimum weight of drums is 10 lb (4.5kg).

Brake master cylinder must remain stock and in the stock location.

Right or left brake pedal may be removed.

One brake proportioning valve is permitted per car.

Complete elimination of the brake at any one wheel is **PROHIBITED**.

**Any car found to be in breach of this rule will incur an automatic and immediate suspension.**

## **9. BUMP STEER**

Adjustments to the bump steer settings will only be permitted by placing spacers between the steering rack and the heim ends of the tie rods or between the front spindle pick up points and the heim ends of the tie rods. No other modifications to adjust bump steer such as changing the height of the steering rack or modifying the spindles are permitted.

## **10. BUMPERS AND TOW HOOKS**

Front bumpers must remain standard as supplied by USLCI and stamped by INEX or LCA including tab thickness and length. One bolt is required per tab.

Rear bumpers and tabs must remain standard as supplied and stamped by INEX or LCA, with the exception of a diagonal brace on each side extending from the centre of the radius bend, back to the rectangular chassis section. This brace is to be of the same material type and dimension as the bumper and not exceed 300mm in length.

All bumper tabs must have minimum length of 25mm from the chassis end to the rear of the bumper. Should the tab become bent and therefore shortened it shall be repaired or replaced before competing again.

Bumpers are to be affixed to the car with one bolt per tab as supplied by USLCI and stamped by INEX or LCA. No welding, tie wire, taping etc. 330mm straps must be fitted. M12 tow hooks must be mounted at left and right hand front chassis rail and left and right hand rear chassis rail (**NOT** through bumper tabs).

## 11. BUMPER STRAPS

All bumper bars are to be fitted with two seat belt straps.

The straps are 330mm seat belt straps with eyelets at each end.

The front straps must be mounted to the lower grill mounting points. They must not be mounted to the front bumper bolts or tow hook bolts. Two additional 3/8" (10mm) bolts are permitted to be added to the left and right hand side of the front clip to secure straps if room allows. See alternate position for grill mount below.

The rear bumper straps must be mounted to the left and right hand tow hook mounting bolts. They must not be mounted to the rear bumper bolts. See photograph 5 below.

### BUMPER SAFETY STRAPS

Bumper Safety Straps are to be seatbelt extensions with eyelets, measuring 13" (330mm). They must be mounted as per the photographs below.

On the front, the straps are to be mounted using the lower grill mounting points. Bolts may be increased to 3/8" (10mm). Two additional 3/8" (10mm) bolts are permitted to be added to the front, on the left and right hand side of the front clip to secure straps if room allows. This ensures the straps will hold the bumper high enough off the ground to prevent it being caught under the front wheels.

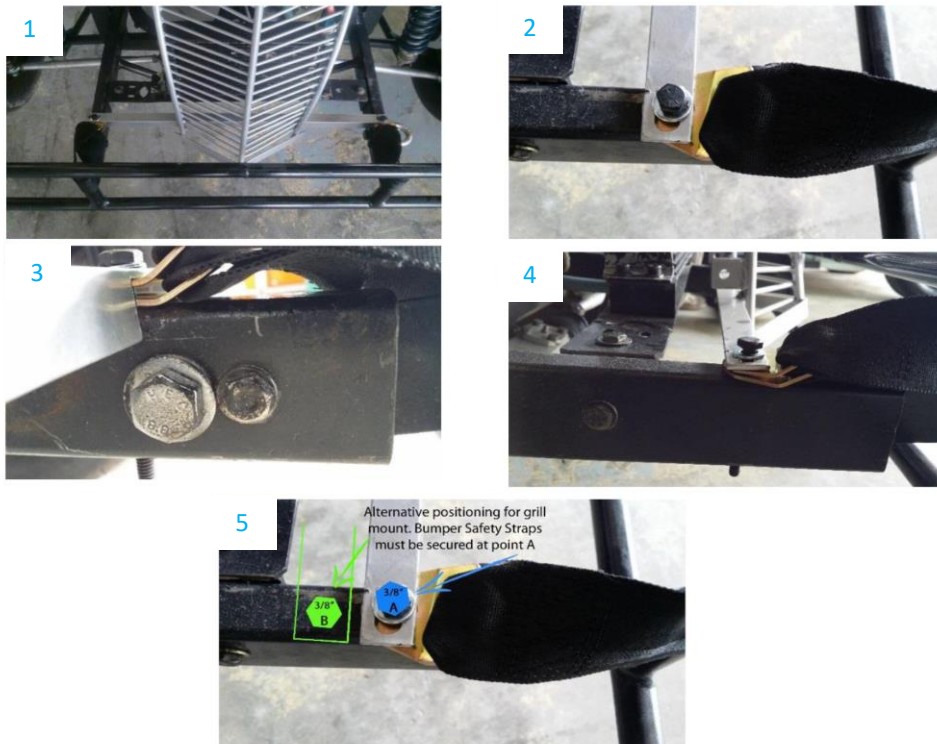

At the rear of the car, the straps must be mounted using the tow hook mounting bolts. They must not be mounted to the rear bumper bolts.



Under NO circumstances are any tow hooks to be fitted through any bumper tabs.

## 12. CARBON FIBRE

No carbon fibre is permitted on a Legend Car.

### 13. CARBURETORS

The carburetors and components of same must remain stock Yamaha FJ1200/XJ1200/XJ1250 as currently delivered by USLCI. Only carb jets, needles, slide springs and butterfly screws may be replaced.

No other modification to the carburetors or components of carburetors is permitted.

### 14. CAR/DOOR NUMBERS

Cars shall have door numbers on both sides of the car that are minimum height of 400mm and minimum width of 100mm, or to the satisfaction of LCA with written permission.

Any such written permission must be noted in the Log Book by LCA officials.

Roof numbers are permitted on the roof surface but are not compulsory. All cars must have the car number visible on the front and rear of the car, minimum height 100mm, minimum width 25mm. These numbers are to be placed on the Front Right guard and the Rear Left guard.

Car numbers will be allocated a State or Territory suffix. "A" for ACT Region (Braidwood, Marulan, Yass, Cooma circle), "N" for NSW, "NT" for Northern Territory, "Q" for Queensland, "S" for South Australia, "T" for Tasmania, "V" for Victoria, "W" for Western Australia. The suffix "NZ" will be used for New Zealand. Suffix lettering must be a minimum height of 100mm.

Competitors must apply in writing to LCA for allocation of a number and LCA will confirm the allocation to that competitor in writing.

Numbers will remain the property of LCA and cannot be sold privately. Numbers will not be transferable between competitors without LCA consent. LCA has the final say on number allocation. A holding fee of \$50 per year is to be paid to LCA to hold a particular number for a maximum of 1 race season. If you do not own a car, your number will be forfeit after one month.

A waiting list will be maintained by LCA and anytime a number becomes available, the first name on the list with that number as their preference will have first option on that number.

**Please contact LCA for allocation of numbers.**

Legend Car # AUS 1 shall be allocated each year to the Australian Title holder from the previous season. All other numbers 2 – 99 may be used in each State or Territory and New Zealand.

All cars will run a small sticker on the right rear guard, to identify their INEX division to other drivers.

PRO



SEMI PRO



MASTER



### 15. CAR WEIGHT

The minimum ***combined*** car and driver weight is 1300lbs (590kg). No minimum car weight will be applied, however all cars are to remain 'as delivered' and no deliberate 'lightening' of cars is allowed. Breach of this rule will result in disqualification and possible suspension.

Competitors are ***NOT*** permitted to add fuel after an event to meet minimum weight requirements.

***It is the driver's responsibility to ensure the car meets the minimum weight requirement of the measuring device used by LCA officials at that track.***

## **16. CHROME PLATING AND POLISHING**

External parts such as bumpers, Nerf bars, suspension components and cam cover may be chrome plated or polished.

## **17. CLUTCH MASTER CYLINDER**

The clutch master cylinder must remain stock as supplied by USLCI and stamped by INEX or LCA in the standard location with no alterations.

Clutch pedal arm may be shortened to suit the driver.

## **18. COILS, COIL LEADS AND SPARK PLUG BOOTS**

These components must be stock Yamaha parts to suit the engine used, stock grey INEX coil wires or any 8mm aftermarket coil wire (EG Bosch, Eagle etc.) or red Dynatek coils marked with the INEX logo as supplied by USLCI and stamped by INEX or LCA.

The spark plugs may be aftermarket type with the same thread size. The stock coil mount must not be altered in any way and may only be replaced with an INEX or LCA approved coil mount.

## **19. DRIVESHAFT**

Driveshafts, flanges, and U joints must remain standard as supplied by USLCI and stamped by INEX or LCA with no lightening or alteration of any component.

Driveshafts must be painted white or light grey.

## **20. ENGINE COATINGS**

Coatings as delivered stock from the factory are permitted throughout the engine.

Headers may be painted with heat resistant paint only, or wrapped in heat wrap tape.

Repainting the engine or using an unpainted engine is permitted.

## **21. ENGINE COOLING**

Extra fans, remote oil cooler, remote oil filter, header wrap, holes in the hood, holes in the front fenders, heat shields between carburetors and cylinder heads and mud shields in front of oil cooler are permitted. None of these items shall direct forced air into the air filters on the carburetors.

The size of holes in the hood shall not exceed a combined total of 54 square inches.

Hood louvres are permitted, maximum 3/8" (9.5mm) high and must not exceed the width of the hood.

Louvres must not direct air onto the air filters. Total area of louvre opening and hood vents combined, must not exceed 54 square inches.

Air scoops on bonnets are permitted. Scoops must not exceed 1.5" (38.1mm) in height, 10.5" (266.7mm) in width and 16.5" (419mm) in length.

SAAS Bonnet scoops are recommended.

## **22. ENGINE SERIAL NUMBERS**

All engines must carry a serial number on the casing. Any engine without a serial number must be inspected and stamped by LCA prior to being sealed.

## **23. ENGINE LOCATION AND MOUNTS**

Left and right side engine mounts must remain within the stock dimensions, thickness, configuration and location as supplied by USLCI and stamped by INEX or LCA. The right side engine mount may be replaced with the optional mount supplied by USLCI and stamped by INEX or LCA. With the use of the optional mount on the right side, the original mounts on the engine on the right hand side may be removed.

The engine mounts must remain in the stock location on the chassis rails.

Mounts must remain bolted to the chassis, **NOT** welded.

## **24. ENGINES**

The only engines permitted are Yamaha:

XJR 1300

XJ 1250

XJ 1219

XJ R1200

FJ 1200

FJ 1100

Only two (2) oversizes for XJR 1250/XJR 1300 Sealed Engine + 4Thou and +8Thou.

All engines are to be checked and sealed. All engines will be measured and sealed by LCA prior to racing or tech sealed in the interim at the discretion of LCA or Officials. One week's notice is to be given to check and reseal the engine at a cost of \$100 to the owner. All engines are to be brought to Goulburn HQ for testing and resealing.

LCA reserve the right to install a Tech Seal at the track if necessary. The engine should be inspected and sealed prior to the next round. If the engine is deemed non-compliant at that time, all points for Tech sealed rounds will be lost.

***Engines not sealed by LCA will be disqualified from the event.***

## **25. EXHAUST SYSTEM**

The headers, muffler and gaskets must remain within the stock dimensions, steel thickness, locations and configurations as supplied by USLCI and stamped by INEX or LCA. The internal and external components of the header and muffler must not be altered in any way, with the exception of muffler retaining tabs, wires, springs or chains associated with the retention of the muffler for safety reasons.

Stock USLCI S&S exhaust systems are mandatory.

Heat wrapping on the headers is permitted.

The muffler must have restraints fitted to prevent the muffler becoming dislodged during the racing. \*\*See 50 Mufflers

## **26. FENDER MOUNTING**

Stock fender mounts must remain and must not be altered. No additional supports or mounts permitted. All 37 Ford grills must use the inner mounting hole closest to the grill. Cars that use a Fibreglass grill shell may remove the original fender brackets.

Area under the rear fenders – removal of the fibreglass section of the body underneath the rear fenders is permitted to allow for easier access to rear suspension components. Removal of any body section under the rear fenders must not affect general appearance.

## **27. FENDER HOLES AND TRIMMING**

Holes are permitted in front fenders with a maximum of 10 holes per fender. Maximum diameter of each hole is 100mm.

Trimming of front fenders on the engine side of the fender is permitted to allow clearance around headers and air filters, and must be minimal. Minor trimming allowed around grill and running boards to allow fitment only.

Rear fenders are not permitted to have holes or vents. Rear fenders may have the wheel arch section trimmed to allow for type clearance but must be minimal to retain appearance.

## **28. FIBREGLASS COMPONENTS**

All fibreglass components must remain of stock dimension, thickness, location and configuration as supplied by USLCI or LCA. All panels must be fibreglass and approved by USLCI or LCA. Trimming of guards or body panels is not permitted.

Fibreglass panels must not be intentionally lightened or reinforced.

The use of a complete front end (hood, fenders and grill) on a different model car is permitted.

## **29. FIREWALL**

A steel/aluminium fire wall as supplied by USLCI and stamped by INEX or LCA is mandatory. A thicker than stock firewall can be installed.

## **30. FRAME**

Absolutely **NO** modifications of the frame or roll cage are permitted.

Any special requests or unusual repairs must be submitted in writing to LCA and, if granted, approval for such requests will be given in writing and must be kept available to officials at any time during a race event.

VIN number plates **MUST NOT** be removed or transferred to another chassis under any circumstances. Any participant found to be in breach of this rule will incur a lifetime ban from Legend Car racing in addition to heavy fines. No exceptions shall be made.

Only frames produced by USLCI and stamped by INEX or LCA may be used.

Frame Update – As of January 1, 2000, all Legend Car frames (coupes & sedans) with 0.065" E.R.W. main roll cage will no longer be eligible for competition in the Legend Car Series.

All frames must be replaced with a 0.083" D.O.M. main roll cage frame. It is estimated that all frames produced before August, 1995 do not meet the above 0.083" D.O.M. requirements. All cars & frames running as Legend Cars must be produced by USLCI. All cars must carry the serial number assigned to that frame. This plate shall not be tampered with in any way.

**Metal Fatigue** – It is highly recommended to have the frame checked periodically by an expert for metal fatigue. Cracked or broken frames are strictly prohibited from any LCA/INEX sanctioned events.

**Suicide Doors** – Doors with the latch on the A-Pillar and hinges on the B-Pillar rather than the traditional method of the latch on the B-Pillar and the hinges on the A-Pillar. Suicide doors are only permitted on the 1934 Ford and Chevy Coupe frame.

If the chassis should become severely damaged, replacement frames must be purchased through USLCI authorised dealer only.

Front and rear clips may be replaced with approved front and rear clips supplied and stamped by INEX or LCA. Repairs to front and rear clips are permitted as per the image below.

## Front and Rear Clip repair zones.

Only the areas colored green may be repaired or replaced.  
Anything beyond these zones requires a new clip.

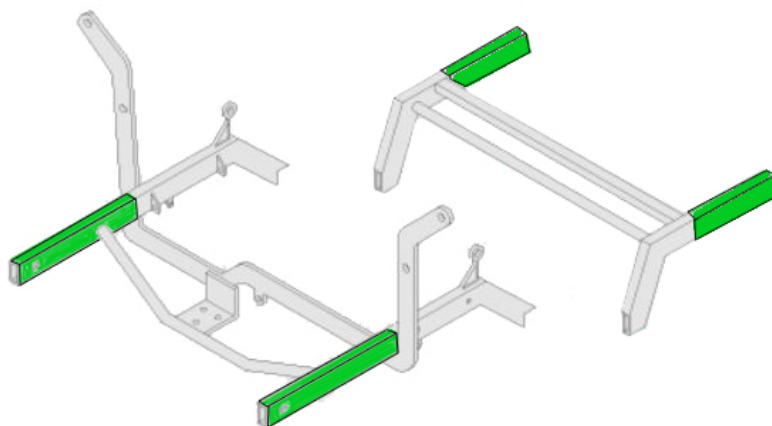

The main roll cage and drivers compartment is **NOT PERMITTED** to be replaced or repaired if damaged beyond the presiding technical officer's satisfaction.

LCA reserves the right to make the final decision with regard to the integrity of the rollcage/chassis.

### **31. FUEL**

The only fuel allowed is commercially available petroleum based fuel available from multi outlet services stations, maximum octane99.

**NO** ethanol blend "E85", methanol, Elf or other brands of racing fuels are permitted.

**NO** additives are permitted. **NONE**.

LCA reserves the right to specify and/or supply at cost a designated fuel for specific events.

### **32. FUEL CELL**

All fuel cells are to be as supplied by USLCI and stamped by INEX or LCA and remain in the stock location.

All fuel cells must incorporate the use of foam blocks inside the fuel cell.

***The car number must be clearly marked on the fuel cap.***

Red plastic fuel cells with the cap diameter of 5 5/8" (14.2cm) or larger must no longer be used after a July 2014.

Fuel cooling devices are not permitted.

### **33. FUEL FILTERS**

Aftermarket fuel filters are permitted. Plastic fuel filters are allowed.

**NO** glass filters.

Fuel filters must be located in stock location behind the driver's seat firewall.

### **34. FUEL LINES**

Fuel lines **MAY NOT** be located in or run through the driver's compartment.

Steel braided fuel lines are mandatory.

Fuel lines are **NOT** to come in direct contact with electrical wiring. Fuel lines may be run through a sleeve and cable tied to wiring for safety.

### **35. FUEL VALVES AND REGULATORS**

Aftermarket fuel shut off valves and regulators are permitted.

### **36. FUEL PUMP**

Fuel pumps must be stock as per supplied by USLCI and stamped by INEX or LCA.

Fuel pumps must be wired to the engines electrical system so that when the engine is turned off electrically, so does the electrical supply to the fuel pump. The fuel pump should cease to operate when the engine stops. Fuel pump shall be securely mounted to the roll cage in the stock location as supplied by USLCI.

### **37. GAUGES & SWITCHES**

Only analogue gauges that record or display the following are allowed:

Cylinder head temperature.

RPM.

Oil pressure.

Oil temperature.

The only digital gauges permitted are gear selection indicators.

Oil pressure gauges must use steel braided lines.

All switches must be clearly identified and marked accordingly.

### **38. GEAR RATIOS**

The only rear end gear ratios permitted are to be within the range of 2.50 to 4.30.  
The gears must remain within the stock dimensions, thickness, weight, location and configuration as supplied by USLCI and stamped by INEX or LCA.

### **39. GEAR SHIFTER & KNOB**

Gear shifter is to remain stock, as delivered by USLCI (Part # 110X00X202). Gear knob may be stock or driver choice, but must be no higher than 200mm from tunnel cover when lever is in the upright position. Gear knob choice may not be offensive in any manner.

### **40. GUSSETS**

No removal or strengthening of gussets without written approval from LCA.

### **41. HEIM ENDS**

Only magnetic steel heims as currently supplied by USLCI and stamped by INEX or LCA or heims of very similar appearance and dimension are permitted.  
Aluminium heims are **NOT PERMITTED**.

### **42. IGNITION SYSTEM**

The complete ignition/engine control system must be the original OEM parts for the motor (INEX approved).  
Electronic throttle/traction controls are not permitted.  
In line fuses only, **NO** fuse blocks.  
Ignition pick up coil wires must run directly to the ignition box and may not be taped, tied or wrapped to other wires or fuel lines.  
No open wires or unused connectors allowed within reach of the driver.

### **43. IGNITION CONTROL BOX**

The stock ignition box that was the OEM supplied unit (black box), or red INEX approved ignition box are the only boxes permitted for use. They **MUST NOT** be altered or relocated in any way. Only one ignition box is permitted. The OEM black box ignition must not exceed the capability of 10,500 rpm.  
LCA reserves the right to substitute an ignition box at any time, on any car. Failure to comply will lead to expulsion from that event and possible fines and/or suspension. LCA will not be liable or responsible for any engine failure or damage that may result whilst using a LCA supplied ignition box.  
Blue box ignition boxes or any other type of device that allows ignition timing to be altered are not permitted.

#### 44. IGNITION ROTORS

Ignition rotors must be the stock OEM supplied part or the rotor supplied with an INEX red ignition box as supplied by USLCI and stamped by INEX or LCA. No aftermarket electronic ignition advancers are permitted.

#### 45. IGNITION PLATES

The ignition plate must be the stock OEM supplied part or the plate delivered with the INEX red ignition box as supplied by USLCI and stamped by INEX or LCA. It may be slotted to advance the ignition timing of the engine. The ignition pickup cover is not mandatory.

#### 46. JAM NUTS

At least one jam nut per radius rod and one jam nut per ball joint is required.

#### 47. KILL SWITCHES

Kill switches ***are mandatory*** for the 18/19 season. Approved parts and placement are shown below. ***No modifications or alternate placement is permitted.***

##### RRS FIA Battery Master Cut-Out Switch

The RRS FIA Battery Master Cut-out Switch will ensure complete electrical shutdown on a running competition car when operated. It also prevents damage to the alternator diode and prevents engine run on when operated. Suitable for 12V use and should be used with 10mm diameter battery terminals. Supplied with resistor.

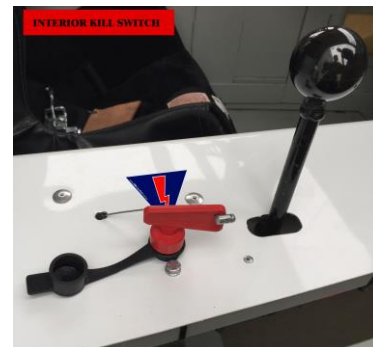

##### Pull Cable

Pull cables suitable for remote operation of mechanical battery cut-off switches. The cable is supplied with an inner cable and outer sleeve with a threaded section to allow it to be mounted to a panel or bulkhead. This cable is to be mounted to the left hand front side panel as per picture below and clearly marked with an FIA approved electrical decal.



#### 48. LOWER CONTROL ARMS

The lower control arms must remain stock and as per dimensions supplied by USLCI and stamped by INEX or LCA. Each measurement shall have a tolerance of + or – 1/8" (3mm).

#### 49. MANDATORY DECALS

All registered Legend Cars are to display LCA stickers (provided at Registration) on left and right rear panels as per image below.



The current Series Sponsor visor sticker is to be affixed to the windscreen at all events. New stickers will be provided at Registration and replacement stickers can be obtained from LCA in the event of damage. The sticker must remain 100mm in height but may be trimmed at the outer corners to fit windscreen shape. Scrutineers have the right to deny a car entry to an event if the visor sticker is not affixed or affixed in a manner deemed unacceptable.



LCA reserves the right to insist cars display a sponsor, association or incorporation logo at selected events.

Failure to comply will result in RoF penalties for **ALL RACES** including Feature and no points allocated for that event.

#### 50. MIRRORS

Mirrors are not permitted.

## **51. MUFFLERS**

Mufflers such as stock Legends S&S are to be as supplied by USLCI and stamped by INEX or LCA. Mufflers must remain stock and must not be modified in any way except external tabs or mounts to assist in retention of the muffler.

Exhaust must be mounted and fixed to the factory mounts (pushed tight together).

Generally a chain of 3/16 thickness links fixed around the muffler outlet with the use of a hose clamp and the chain then bolted to the chassis gusset located nearby is sufficient. Other methods of retaining the muffler in place may be approved by the presiding technical official of LCA.

## **52. NERF BARS**

The Nerf bars must remain within the stock dimensions, thickness, location and configuration as delivered by USLCI and stamped by INEX or LCA. No other type of Nerf bar is permitted. Nerf bars must not be used to hold ballast.

## **53. OIL CATCH CANS**

An oil catch can (max 17oz (500ml) capacity) may be used. It must be securely fastened and remain within the engine compartment. It may only be routed to by a hose from the stock crankcase breather opening or the oil fill cap.

## **54. OIL COOLERS AND LINES**

Oil coolers must be cooled by the flow of air only. All oiler coolers and lines must be located forward of the front fire wall. More than one oil cooler is permitted. Fans are permitted on oil coolers. Oil coolers **MUST NOT** be mounted below the bottom of the front bumper. After market oil coolers are permitted.

A shield securely fixed may be used to prevent dirt blocking the cooler, any such shield shall not exceed the front cooling core surface area of the cooler by more than 20%.

## **55. PICKUP POINTS AND SPACERS**

Absolutely **NO** modifications of the frame pickup points, rear end pickup points or spindle points are permitted. A maximum 3/4" (1.9cm) wide spacer may be used on all 1/2" (1.2cm) suspension bolts.

## **56. RACK AND PINION STEERING**

Only the rack and pinion steering box as currently supplied by USLCI and stamped by INEX or LCA may be used. **NO** other steering box is permitted.

## **57. RACE CAR APPEARANCE**

Competitors must present a neat, clean and stock appearing car for any LCA sanctioned event. Race damaged cars must be repaired to the satisfaction of the presiding technical officer before returning to competition.

LCA reserves the right to deny entry of a car into race competition if in the opinion of LCA or their representatives, that car is deemed to be damaged or untidy or the car has inappropriate sponsorship, advertising, paint scheme or lettering that is not in good taste or deemed offensive.

## **58. RADIUS RODS AND PANHARD BAR**

The radius rods and panhard bar must be within the stock dimensions, thickness, location, material and configuration as supplied by USLCI and stamped by INEX or LCA and **MUST NOT** be reinforced in any way. **NO** steel radius rods or panhard bars are permitted. The 11" (279.4mm) and 12" (304.8mm) rods may be interchanged anywhere on the car as long as the car still meets all specifications contained in this rule book.

## **59. REAR AXLES**

The only axles permitted are the type that are supplied by USLCI and stamped by INEX or LCA and must not be lightened or strengthened in any way. All one piece axles must be stamped by INEX or LCA.

## **60. REAR ENDS**

Only 10 bolt pattern/wide flange (5/8") Toyota, locked steel rear ends are permitted. All rear end components including the housing and pickup points must meet the stock specifications of the stock component as supplied by USLCI. The rear end must be locked, all spider gears welded. Steel spool as supplied by USLCI and stamped by INEX or LCA.

**NO** limited slip diffs, aftermarket gears, quick change rear ends, floaters, homemade or otherwise are permitted.

Only OEM bearings are permitted.

**NO** spacers are permitted between the backing plate and bearing. Axle tube material must be 3" O.D and 0.120" wall thickness. Double shear rear end housing is available through INEX or LCA and may be used.

## **61. REAR OFFSET**

There must be a minimum of 6" between the inside edge of the rear brake drum and the rear frame rails (directly below the centreline of the rear end housing) on both sides. No wheel or axle spacers are permitted.

## **62. REMOTE OIL FILTERS**

Remote oil filters are permitted and must be mounted in the engine compartment only. Inside or outside mounting of the remote oil filter to the frame rail is permitted. The remote oil filter must be located in a position where it cannot be easily damaged in the event of an accident. Remote oil filters may not be mounted below the bottom of the front bumper. Filter must have a hose clamp around it, safely wired to the mount (to prevent it from “backing off”).

## **63. RIDE HEIGHT**

The car may have no less than 3 ½” (90mm) between the bottom of the frame rails (not the weld) and the ground. This measurement is to be checked without the driver in the car, as raced, without lifting of the car in any way.

## **64. RUNNING BOARDS**

The running boards must remain within the stock dimensions, steel thickness, location and configuration as supplied by USLCI and approved by INEX or LCA. **NO** reinforcement permitted.

## **65. SHEET METAL**

The minimum thickness of sheet metal is 0.036”. All sheet metal panels are to remain the same size, appearance and location as supplied by USLCI and stamped by INEX or LCA. The fuel cap access hole must be covered and secure.

## **66. SHOCK ABSORBERS**

All Legend Cars must use the INEX or LCA stamped Bilstein shock absorbers as supplied by USLCI and stamped by INEX or LCA. Shock absorbers may be mounted either way up.

The upper part of the shock may be mounted inside or outside of the frame.

Shock bumpers are permitted, max thickness ¼” (6.35mm).

Absolutely no tampering or alteration of external or internal components, fluids or gases permitted.

## **67. SPINDLES**

The spindles must remain stock, within the stock dimensions, thickness, location and configuration as supplied by USLCI and stamped by INEX or LCA.

Repairing a cracked or broken aluminium spindle is **NOT** permitted.

Only alloy spindles as issued by USLCI or LCA are permitted, **NO** steel versions are allowed.

## **68. SPRINGS**

All Legend Cars must use a 10" (25.4cm) or 8" (20.32cm) spring. Any spring weight combination and aftermarket springs of stock design are allowed. Barrel springs are not permitted. One spring per shock.

Spring rubbers are **NOT** permitted.

## **69. SPROCKET ADAPTORS**

This item must remain stock as supplied by USLCI and stamped by INEX or LCA.

**NO** lightening or modifications of any type. A set screw to retain sprocket nut is permitted.

## **70. STEERING COLUMN**

The steering shaft or steering column bracket may be modified to suit driver comfort or safety by altering the length of the shaft or by altering the steering column bracket that connects to the dash. Dash bracket must remain steel. Bearings are not permitted to be used in mounting the steering shaft. Stock style bushings or steel rod ends must be used. Intentional lightening of any component is **NOT** permitted. A hose clamp or shaft collar is mandatory on the steering column in the engine bay and driver's compartment sides of the tube that houses the steering column.

There can be no more than a 0.24" (6mm) gap between the bushing and the clamp/collar.

Modification of the driver's compartment roll cage is **NOT** permitted.

Tubing used for steering shafts must be stock as supplied by USLCI.

Upgraded steering universals are permitted.

Steering quickeners are **NOT** permitted.

## **71. STEERING WHEELS**

Aluminium or steel Steering wheels may be used. Size may be increased or decreased from stock size.

Racing style, quick release steering hubs are **mandatory**.

## **72. TRACTION CONTROL DEVICES**

**NO** electronic traction/wheel devices are permitted.

## **73. TYRES**

Providing testing is favourable, as of the 2019 Australian Title on 7 March 2019, the only tyres permitted for competition will be stamped Legends/INEX MRF tyres. The stamped USLCI American Racer MD57, 71" tyre may be used up until that date, but MRF tyres will be mandatory for the 2019 Australian Title and all races following that date.

Scrutineers are to note in the Log Book, which tyres a competitor starts each meeting with, and those tyres must be used for the duration of that meeting. It is not permitted to swap between MD57 and MRF tyres during the course of a meeting to give an advantage due to track condition, unless permission is given for testing purposes.

Tyres must not record a reading of less than 45 on a durometer.

Any tyre that does not meet the minimum durometer reading of 45 will be confiscated by the Scrutineer for further testing and may be destroyed at the discretion of the presiding technical officer.

**It is the responsibility of car owners and drivers to ensure their tyres comply with the measuring device used by scrutineers.**

Tyres used on the car are **NOT** to be recapped, repaired, patched, siped, buffed, ground, machined down, soaked or softened.

**NO** substance that softens or alters the compound shall be used on the tyre footprint area.

Tyre shine or appearance enhancer may be used on the **side walls only**.

Cars must **NOT** have any tyre other than the prescribed tyres at any time during the course of a race meeting including transport through the pit area.

Heavy penalties will be imposed by LCA for any driver in breach of these rules relating to tyres.

Tyres to be run stock. **NO** grooving allowed.

#### **74. UPPER CONTROL ARMS**

The upper control arms must remain stock, within the stock dimensions, steel thickness, location and configuration as delivered by USLCI and stamped by INEX or LCA. Tolerances + or - 1/8" (3.18mm).

#### **75. WHEELBASE**

All cars must compete with 72 3/4" (184.78cm) to 73 1/4" (186.05cm) wheelbase on either side.

**Measuring wheelbase** – The measurement will be taken with the front and rear tyres on one side in line with each other. To determine this, the measuring tool or tape measure must touch three points. These points are the front of the rear tyre sidewall and the front and rear of the front tyre sidewall. The measurement is then taken from the front edge of the front wheel to the front edge of the rear wheel. The process is the same when measuring wheelbase on the opposite side.

#### **76. WHEELS**

Any type of automotive wheel that has a 13" (33cm) diameter, a 7" (17.8cm) width and the offset of 3" (7.6cm) to 3 1/4" (8.25cm) from the back rim edge to the back of the wheel centre is permitted. All wheels must be magnetic steel, **NO** alloy wheels permitted.

**NO** wheel weights are permitted. Bleeder or relief valves are **NOT** permitted.

INEX or LCA approved beadlock wheels must be used on the right rear, but are optional elsewhere. **NO** wheel spacers are permitted.

#### **77. WIDTH**

The total overall width of the car (front and rear) may not exceed 61 inches (154.94 cm) with USLCI American Racer MD57 tyres. The car must be able to roll freely through a 61" (154.94 cm) wide opening as raced.

## **78. WINDSHIELDS**

Windshield (mesh) must remain stock as supplied by USLCI and LCA.

Sun visor maximum 110mm to be used at the top of the windscreen opening. Must be of flexible plastic type material and be securely fixed. LCA reserve the right to advertise series or other sponsors in this location. Failure to comply will result in RoF penalties for **ALL RACES** including Feature and no points allocated for that event.

An LCA certified Safety Grill is mandatory for all Legend Car competition in Australia. LCA certified grills are identifiable by the certification stamp.

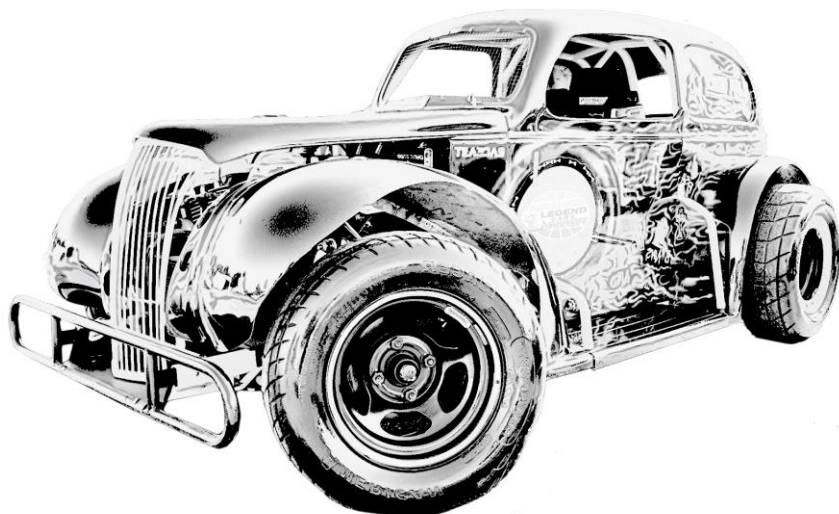

## **PART FOUR**

### **CAMSHAFTS**

Camshaft modifications are not permitted in sealed XJR 1250/XJR 1300 Engines.

Camshaft chains must remain stock as delivered by Yamaha.

Stakeable link can be used.

Camshafts may be pinned.

**NO** aftermarket Cam chain gears or slotting of bolts is permitted.

### **CLUTCH**

The clutch plates and springs may be replaced with aftermarket types of the same design.

**NO** aluminium clutch plates allowed. Aluminium Clutch baskets permitted.

Heavy Duty Clutch is permitted.

## **CYLINDER HEADS**

All engines must retain the casting marks on inlet and exhaust ports.

All engines are permitted to have valve seat inserts reworked or replaced with aftermarket seats of original dimensions. The stock I.D at the bottom 1/16" of the intake port is 0.99.", the exhaust port shall be 0.830". No porting of any area below the valve seats.

"O" ringing of head or block is **NOT** permitted.

Relief cuts for cc balancing must not exceed the bore size.

Repair welding on heads is permitted but must remain stock configuration.

Compression ratio shall **NOT EXCEED** 1200 - 10.0 to 1 max and 1250 - 10.4 to 1 max. The cranking compression (determined by 10 to 12 revolutions) must not exceed 165 psi whether the engine is hot or cold with the throttle wide open.

The compression gauge used by scrutineers is the official gauge. It is highly recommended that engines be set at a cranking compression of less than 155 psi to allow for variances in measuring equipment.

Crankshaft must remain stock.

No modifications to throw balancers or weight of the crank and no polishing permitted.

Minimum crankshaft weight is 27 lbs (12.2 kg).

Pistons may be oversize type up to 0.022" from stock; pistons must remain complete with no alterations.

Worn cylinder sleeves may be replaced with aftermarket types.

**NO** polishing of Conrods.

Aftermarket rod bolts permitted. All Conrods must be as per original assignment, e.g. no 1250 rods in a 1200 engine.

Cutting the dome on 1200 pistons is allowed in order to achieve 10.0:1 compression ratio.

Engine stroke must remain standard.

## **1200 CRANKING COMPRESSION**

The cranking compression of a sealed engine must not be at or below 165 psi at any time (hot or cold) on at least three (3) cylinders with the ignition off, the throttle wide open, and with the carburetors on the engine. Ten to twelve revolutions of the engine will determine the total compression of the cylinder. Cam timing may be adjusted accordingly to meet the requirements of this rule by slotting the cam sprocket gear or substituting with an aftermarket cam gear sprocket.

INEX highly recommends that you have your engine set at 155lb. cranking compression instead of right on the line at 165lb. to allow for slight variations between gauges. There is no tolerance for engines over 165lb. The gauge used by the Tech Inspector is the "official gauge."

## **PART FIVE**

### **VALVES**

The only alterations to valves are the angles on the valve seat, with a maximum back cut width of up to 0.020" from the edge of the valve. Only stock valve lifter and adjuster shims may be used.

Valve guides must remain within the stock dimensions.

Valve springs may be replaced with aftermarket steel magnetic types only. Stock spring retainers and clips/keepers must be used.

### **TRANSMISSION**

The transmission and associated gears must remain standard with the only alterations permitted being the installation of shims to assist with proper gear engagement.

### **OIL PUMPS, PANS AND OILING SYSTEMS**

Oil pumps must be of stock dimensions, with the only alteration being the installation of shims in the relief valve.

Oil pan must remain stock, no alternations.

Oil lines may be diverted to suit remote oil coolers, filters or camshaft oilers (commonly known as top oilers).

## **PART SIX**

### **REGISTRATIONS**

All race cars must be registered with LCA, have the Logbook available and carry an LCA approved registration sticker valid from 1 Jul to 31 Jun of the current year. Registration sticker must be fixed to the Roll Cage on front left hand side parallel cross bar. VIN Plate must also be affixed to the chassis on the middle right cross bar below gear shift.

All cars and frames racing as Legend Cars must have been produced by USLCI and stamped by INEX or LCA.

Cars not registered with LCA and not having a registration sticker approved by LCA will not be eligible to compete in Australia.

Registration stickers must not be damaged, removed or transferred to another car or chassis.

Registration Fees include INEX membership for one driver, a second driver for the same car will incur an additional fee of \$100 to cover INEX membership costs.

### **NOMINATIONS**

All nominations are to be completed on line through the Legend Cars Australia website, [www.legendcarsaustralia.com.au](http://www.legendcarsaustralia.com.au). Unless noted in 'further details', in the individual event, all nominations will close at 9am on the Monday prior to the race date. The nomination system will remain open until midnight on that day and late nominations can be entered through here. It is the drivers responsibility to read any and all information pertaining to an individual event. ALL entries received after 9am will be considered a Late Nomination. Late nominations will start rear of field and will be awarded finishing points only if heats are run, but no passing points. Failure to notify of a cancelled nomination will result in a \$50 penalty or Rear of Field start for the entire meeting, including Feature race for their next nominated meeting. Rolling starts will be mandatory. New drivers will start rear of field until officials deem them safe to go in the general draw.

A \$10.00 nomination fee will apply as of the beginning of the 19/20 season. Payment will be required at time of nomination. If the nominee elects to pay via the Direct Debit option, the nomination is not considered as accepted until full payment is received. This fee is a Nomination Fee and is charged by LCA. This fee is separate to, and exclusive of any fees charged by the Australian Legend Car Association (ALCA)

Promoters will have the option to allow any nominated driver to start from any position at their discretion in conjunction with LCA officials.

Where tracks are running limited numbers or are capped, first preference will be offered to the top point scores in that Series/Championship. If the numbers are not filled by these position holders then the next position holder numerically is to be given the option of nomination.

Nominations for the Development Series will be accepted when Development Series is running, however, if a Development driver elects to run in the Main division when Development Series is not

running, they will be required to start Rear of Field and their cars must be flagged to indicate Provisional driver to other drivers.

Failure to attend any nominated meeting, without reasonable notification to LCA, will result in RoF starts for all races at the next nominated meeting.

## **TITLE NOMINATIONS**

To be eligible to compete in a National Title or State Title, a Driver must have competed in a minimum of two rounds, or more at the discretion of LCA, in the current season or previous 12 months in the Racing Division for the Title.

At the discretion of the LCA, dispensation can be provided if the Driver has driven in an affiliated class or a Racing Division determined by the Organising Body as providing requisite experience, in the current season or previous 12 months.

The previous year's National Champion and current Australian Title holder shall be permitted to participate in the Australian title event, regardless of the above prerequisites.

**No late nominations for Title meetings will be accepted.**

## **TRANSPONDERS**

All transponders are to be mounted on left or right hand side rail behind tow hook with direct line of sight to the ground (front of car). Incorrectly mounted transponders will result in data not being transmitted to timing system causing a non-classified result.

MyLaps is now in situ at many tracks and transponders are sometimes available for hire at those tracks. However, there is no guarantee MyLaps transponders will be available on any given day. Failure to have a transponder fitted at timed events, will be deemed the responsibility of the driver and that car will not be recorded in official results and no points will be allocated for that event. Transponders may be hired directly from MyLaps for periods of 12 months and more

**Correct mounting of transponder is the driver's responsibility.**

## **ACCOUNTS PAYABLE**

Please contact LCA to obtain an Account application. No credit will be extended unless an Account application and been approved. No further credit will be extended to accounts exceeding 60 days. LCA reserves the right to suspend any current registered car associated with a driver, owner or associate who does not pay their account in a timely manner. Late fees will be applied at 10% of outstanding amount per month on overdue accounts.

**All Legend Cars and Legend Car parts remain the property of LCA until full and final payment is made, including any outstanding late fees applied.**

No other driver will be permitted to participate in any Legend Car event in that car, until the account is settled.

If a car is sold with outstanding amounts owed to LCA, that car will not be permitted to race, nor will it be Registered, until full payment has been received by LCA. It is the responsibility of the purchaser to ensure the car is unencumbered at the time of sale. LCA can be contacted on 02 4821 2888 for all account queries.

Any suspensions will be indefinite from all LCA events until the account is paid in full. The participant will be notified in writing of the suspension. When the account is paid in full, the suspended participant/car will be permitted to compete.

Personal cheques written to LCA with insufficient funds will result in immediate suspension throughout the entire series until the debt is cleared.

The \$120 Interstate Credit previously applied to drivers accounts by LCA, will cease at the end of the 18/19 Season. No Interstate Credits will be applied for Interstate meetings in the 19/20 calendar or for any future seasons.



2019/2020 SERIES SPONSOR (exc WA)

# Narellan POWDER COATING

[www.narellanpowdercoating.com.au](http://www.narellanpowdercoating.com.au) (02) 4646 1584

Narellan Powder Coating is a family-based company located at  
23 Bellingham Street  
NARELLAN NSW 2567

Trevor STARK, (aka Legend Car #33N) and his wife Kylie, accepted the opportunity to purchase the company in August 2017 after managing the business on behalf of others for the previous 8 years.

In that time, the business has grown and expanded, and now accommodates 2 premises enabling the team to cope with the growing workload.

Narellan Powder Coating offer abrasive blasting services, as well as full powder coating services and include commercial, residential and industrial customers in their ever-increasing list of happy clients.

Their works include fencing, tanks, structural steel, household items, car parts (including wheels and chassis) and much more.

They are set up to do lengths of up to 8 metres and 3 tonne in weight.

As the new Series Sponsor, Narellan Powder Coating are offering all members a 10% discount on all powder coating services.

So if you are in need of any powder coating, or have wondered if it's possible on that specific item, call the team at Narellan Powder Coating and they will do their utmost to assist with your requirements.

And remember, if you don't ask the question, you'll never know the answer.

Call Narellan Powder Coating today on 02 4646 1584.

## Narellan Powder Coating - established for over 20 years.

The powder coating process is very similar to a painting process except the 'paint' is a dry powder rather than a liquid. Powder bonds to metal surfaces due to electrostatic charging of the powder and grounding of the parts. Any substrate can be used which tolerates the heat of curing the powder and can be electrically grounded to enhance charged particle attachment. The powder flows and cures during the application of heat.

The main advantages of powder coating over paints are :

- ❖ Powder recovery for reuse
- ❖ More durable than paints

Surface preparation before powder coat application is critical for adhesion and defect avoidance.

## Powder Coating Process

Cleaning » Rinsing » Phosphating » Rinsing » Part Drying » Powder Coating » Curing

2018/2019 AUSTRALIAN TITLE WINNER - #69N Nathan CAMILLERI

Picture by Gary REID



**TAHMOOR RURAL SERVICES**  
0418 427 419 | TAHMOORRURALSERVICES.COM



COMMUNICATION SYSTEMS



DELUXE SCANNER PACKAGES



STANDARD SCANNER PACKAGES



RACING SCANNERS



HEADSETS & ACCESSORIES



TWO-WAY RADIOS & ACCESSORIES



PREMIUM SCANNER PACKAGES



RACE CAR WIRING





# LEGEND CARS AUSTRALIA

Proudly sponsored by



## 2019/2020 DIRT CALENDAR

| MONTH       | DATE | VENUE               | EVENT     | INEX | NOTES    |
|-------------|------|---------------------|-----------|------|----------|
| <b>2019</b> |      |                     |           |      |          |
| SEP         | 14   | VR - PRACTICE NIGHT | PRACTICE  | ✘    | PRACTICE |
|             | 21   | BUNDABERG - QLD     | NRQC RD 1 | ✓    |          |
| OCT         | 5    | VALVOLINE RACEWAY   | STC RD 1  | ✓    |          |
|             | 12   | BEGA                | SRC RD 1  | ✓    |          |
|             | 26   | BUNBURY WA          | WAC RD 1  | ✓    |          |
| NOV         | 2    | NOWRA               | SRC RD 2  | ✓    |          |
|             | 9    | VALVOLINE RACEWAY   | STC RD 2  | ✓    |          |
|             | 9    | BUNBURY WA          | WAC RD 2  | ✓    |          |
|             | 16   | GATTON QLD          | NRQC RD 2 | ✓    |          |
|             | 16   | BUNBURY WA          | WAC RD 3  | ✓    |          |
|             | 30   | VALVOLINE RACEWAY   | STC RD 3  | ✓    |          |
| DEC         | 7    | NOWRA               | SRC RD 3  | ✓    |          |
|             | 14   | ACT SPEEDWAY        | SRC RD 4  | ✓    |          |
|             | 14   | BUNBURY WA          | WAC RD 4  | ✓    |          |
|             | 28   | GRAFTON             | NRQC RD 3 | ✓    |          |

|             |    |                      |                     |   |                                                       |
|-------------|----|----------------------|---------------------|---|-------------------------------------------------------|
| <b>2020</b> |    |                      |                     |   |                                                       |
| JAN         | 4  | GOULBURN             | SRC RD 5            | ✓ |                                                       |
|             | 11 | VALVOLINE RACEWAY    | STC RD 4            | ✓ |                                                       |
|             | 18 | GOULBURN             | NSW TITLE           | ✓ | TITLE RACE                                            |
| FEB         | 1  | VALVOLINE RACEWAY    | STC RD 5            | ✓ |                                                       |
|             | 8  | ADELAIDE SHOWGROUNDS | DEMO ONLY           | ✘ | DEMONSTRATION ONLY                                    |
|             | 8  | GATTON QLD           | NRQC RD 4           | ✓ |                                                       |
|             | 15 | ACT SPEEDWAY         | ACT TITLE           | ✓ | TITLE RACE                                            |
|             | 15 | BUNBURY WA           | WAC RD 5            | ✓ |                                                       |
|             | 22 | NOWRA                | SRC RD 6            | ✓ |                                                       |
|             | 29 | LISMORE              | NRQC RD 5           | ✓ |                                                       |
|             | 29 | BUNBURY WA           | WAC RD 6            | ✓ |                                                       |
| MAR         | 7  | VALVOLINE RACEWAY    | AUST TITLE          | ✓ | TITLE RACE                                            |
|             | 14 | LISMORE              | NRQC RD 6           | ✓ |                                                       |
|             | 14 | BUNBURY WA           | WA TITLE            | ✓ | TITLE RACE                                            |
|             | 28 | VALVOLINE RACEWAY    | STC RD 6            | ✓ |                                                       |
|             | 28 | BUNDABERG - QLD      | NRQC RD 7           | ✓ |                                                       |
| APR         | 4  | GOULBURN             | SRC RD 7            | ✓ |                                                       |
|             | 11 | BUNDABERG - QLD      | QUEENSLAND<br>TITLE | ✓ | EASTER TRAIL<br>TITLE RACE<br>To be run over 2 nights |
|             | 12 | BUNDABERG - QLD      |                     | ✓ |                                                       |
|             | 18 | VALVOLINE RACEWAY    | STC RD 7            | ✓ |                                                       |
| MAY         | 9  | BEGA                 | SRC RD 8            | ✓ |                                                       |
|             | 9  | BUNBURY WA           | WAC RD 7            | ✓ |                                                       |
|             | 16 | GRAFTON              | NRQC RD 8           | ✓ |                                                       |
| JUN         | 7  | WAHGUNYAH            | VIC TITLE           | ✓ | SUNDAY MEETING                                        |

NRQC = NORTHERN RIVERS QUEENSLAND CHAMPIONSHIP  
 SRC = SOUTHERN REGION CHAMPIONSHIP  
 WAC = WESTERN AUSTRALIAN CHAMPIONSHIP  
 STC = SYDNEY TRACK CHAMPIONSHIP  
 TITLE MEETING

